

# FARBERWARE®

P R E F E R R E D



## USE & CARE INSTRUCTIONS 2-SLICE WIDE SLOT TOASTER

FPT200

# IMPORTANT SAFEGUARDS

When using electrical appliances, basic safety precautions should always be followed, including the following:

1. Read all instructions before using Toaster.
2. Do not touch hot surfaces. Use handles or knobs.
3. To protect against electrical shock, do not immerse cord, plug, or Toaster in water or other liquid. See instructions for cleaning.
4. This appliance is not for use by children.
5. Close supervision is necessary when this appliance is used near children.
6. Unplug from outlet when not in use. Unplug and allow to cool before cleaning.
7. Do not operate any damaged appliance. Do not operate with a damaged cord or plug, or after the appliance malfunctions, or has been dropped or damaged in any manner. Contact Consumer Service for return authorization, examination, repair or adjustment.
8. The use of accessory attachments not recommended by the appliance manufacturer may cause injuries.
9. Do not use outdoors or while standing in a damp area.
10. Do not let cord hang over edge of table or counter, or touch hot surfaces.
11. Do not place on or near a hot gas or electric burner, or in a heated oven.
12. Do not use Toaster unattended.
13. Oversized foods, metal foil packages, or metal utensils must not be inserted in this Toaster as they may involve a risk of fire or electric shock. Remove all protective wrappings prior to placing in Toaster.
14. Avoid using items with “runny” frostings, fillings, icings or cheese. This includes pre-buttered foods.

## **IMPORTANT SAFEGUARDS** *(Con't.)*

15. Use Toaster in an open area with 4-6 inches air space above and on all sides for air circulation. A fire may occur if Toaster is covered or touching flammable material, including curtains, draperies, towels, walls and toaster covers, etc, while in operation.
16. Do not defrost or toast convenience foods under any cabinet or overhang.
17. Do not force food into bread slots.
18. Do not attempt to dislodge food when Toaster is plugged into an outlet. Should it be necessary to dislodge food, unplug the Toaster and use only a wooden utensil.
19. Do not clean with metal scouring pads. Pieces can break off the pad and touch electrical parts, creating a risk of electric shock.
20. Keep Crumb Tray clean. See instructions for cleaning.
21. CAUTION: Hot surfaces.
22. Do not use appliance for other than intended use.

## **SAVE THESE INSTRUCTIONS**

**This product is for household use only.**

## ADDITIONAL IMPORTANT SAFEGUARDS

***CAUTION: This product is hot during operation and retains heat for some time after turning off. Always use oven mitts when handling hot materials and allow metal parts to cool before cleaning. Do not place anything on top of the Toaster while it is operating or while it is hot.***

***CAUTION: This appliance generates heat during use. Proper precautions must be taken to prevent the risk of burns, fires or other damage to persons or property.***

1. All users of this appliance must read and understand this Owner's Manual before operating or cleaning this appliance.
2. The cord to this appliance should be plugged into a 120V AC electrical outlet only.
3. If this appliance begins to malfunction during use, immediately lift Toasting Lever manually and unplug the cord. Do not use or attempt to repair the malfunctioning appliance.
4. Use the Toaster on a hard, flat surface. Do not place it near a flame or heat or on a soft surface (such as carpet). Avoid placing it where it may tip over during use. Dropping the Toaster could cause it to malfunction.
5. Avoid electric shock by unplugging the Toaster before cleaning.

### **CAUTION:**

- **DO NOT** toast torn slices of bread.
- **DO NOT** toast small-size breads like "melba", mini-baguettes, breadsticks, etc.

**CAUTION:** A short power supply cord is provided to reduce the risk of personal injury resulting from becoming entangled in or tripping over a longer cord. Extension cords are available from local hardware stores and may be used if care is exercised in their use. If an extension cord is required, special care and caution is necessary. Also the cord must be: (1) marked with an electrical rating of 125 V and at least 10 A., 1250 W., and (2) the cord must be arranged so that it will not drape over the countertop or tabletop where it can be pulled on by children or tripped over accidentally.

## POLARIZED PLUG

This appliance has a polarized plug, (one blade is wider than the other). As a safety feature to reduce the risk of electrical shock, this plug is intended to fit in a polarized outlet only one way. If the plug does not fit fully in the outlet, reverse the plug. If it still does not fit, contact a qualified electrician. Do not attempt to defeat this safety feature.

## ELECTRIC POWER

If the electric circuit is overloaded with other appliances, your toaster may not operate properly. It should be operated on a separate electrical circuit from other appliances.

This product is for household use only.

# GETTING TO KNOW YOUR **FARBERWARE**<sup>®</sup> 2-SLICE WIDE SLOT TOASTER

PRODUCT MAY VARY SLIGHTLY FROM ILLUSTRATION

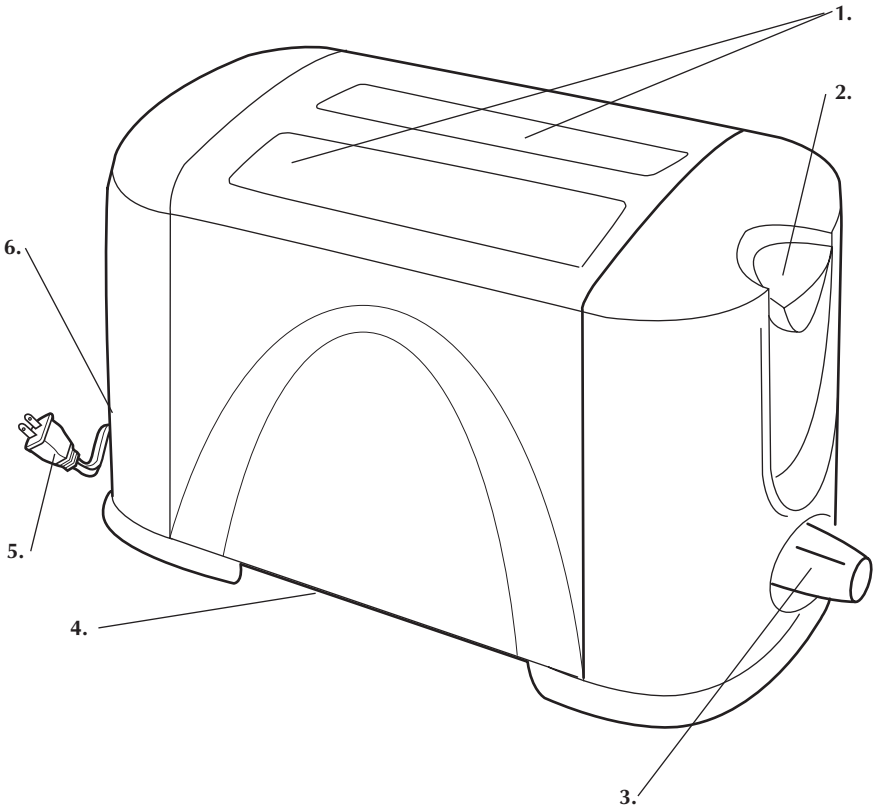

1. Automatic Self-Adjustable Bread Slots
2. Toasting Lever
3. Adjustable Browning Control Knob
4. Hinged Crumb Tray
5. Power Supply Cord with Polarized Plug
6. Cord Storage Compartment

# OPERATING INSTRUCTIONS

## BEFORE FIRST USE

- Carefully unpack your Toaster and remove all packaging materials.
- To remove any dust that may have accumulated during packaging, simply wipe the Toaster exterior with a clean, damp cloth.
- Do not use abrasive cleansers.
- Do not put the Toaster, cord or plug in water.

## CENTERING BREAD GUIDES

Lowering the Toasting Lever closes the Bread Guides, holding the bread centrally in the Bread Slots.

**NOTE:** Bread slice size should not exceed 4.5" x 4.75" x 1" thick.

## SELECTING TOAST COLOR

The Adjustable Browning Control Knob is located at one end of your Toaster. Simply turn the Knob clockwise to the desired toast color: the furthest position to the left is for warming and very light toasting; as you rotate the Knob clockwise, toasting will be progressively darker.

To end the toasting operation turn the toast color knob counter clockwise until the toast pops up or the toaster shuts off.

The first time you toast, it is best to position the Knob at the middle of the range; then adjust each subsequent toasting to your preference.

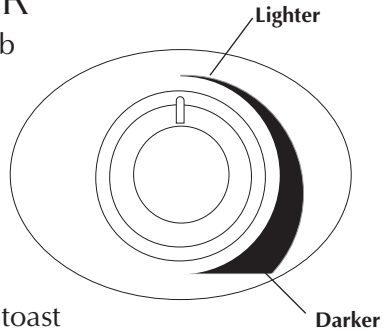

## TOASTING BREAD

1. Place your Toaster on a flat, level surface.
2. Plug power cord into a 120V AC outlet.
3. Adjust the Adjustable Browning Control Knob to the desired lightness or darkness. Turn Knob to the left for lighter toast or to the right for darker toast.
4. Remove all protective wrappings from food before placing in Bread Slots. (Avoid toasting torn slices of bread and broken pastries, which may get lodged in Bread Slots.)
5. Place bread or toaster food into Bread Slots and depress the Toasting Lever. The Bread Slots will automatically center for even toasting.

When toasting a single slice, the bread or toaster food may be placed in either Bread Slot, but may toast slightly darker on the inside than on the outside.

6. Toast will automatically pop up when the selected color is reached.
7. Unplug cord from wall outlet when not in use.

***NOTE: To prevent a risk of fire, never place bread over the opening of the Toaster, but always place it into the Bread Slots.***



## REMOVING LODGED TOAST

If a piece of toast becomes lodged in the Toaster, unplug the Toaster and allow to cool. Press the Toasting Lever down. Turn the Toaster upside down, and shake the toast loose.

***IMPORTANT: Never use a fork or sharp-edged utensil to remove toast. Doing so may damage the heating element or cause injury.***

## PASTRY

For best results, follow the instructions printed on the pastry package. If the package does not have instructions, position the Adjustable Browning Control Knob in the middle. Some pastries may require a second toasting cycle.

***NOTE: Do not use this Toaster for toasting pastry items with runny-type frosting or open fillings.***

## IMPORTANT POINTS

- Remove all protective wrappings from food before placing in Bread Slots.
- For best results, clean Crumb Tray frequently.
- Different breads require different color settings.
- Do not block top openings. Do not place any object over the top openings.
- Do not toast buttered bread or buttered pita bread. Melted butter will cause fire.
- Bread which has been toasted but not buttered may be reheated. Use a lighter setting and watch it carefully.
- When toasting more than one slice of bread, use slices of similar size, thickness and freshness.
- Stale bread, thin bread or sweet bread products, such as tea cakes and fruit loaf, brown much more quickly than ordinary bread, so they should be toasted on the lighter settings.
- Never immerse Toaster in water.
- This appliance is for HOUSEHOLD USE ONLY!
- There are no user-serviceable parts inside. Do not attempt to service this product yourself.
- **Never use a fork or sharp-edged utensil to remove toast. Doing so may damage the heating element or cause injury.**

# USER MAINTENANCE INSTRUCTIONS

This appliance requires little maintenance. It contains no user serviceable parts. Do not try to repair it yourself. Contact a qualified appliance repair technician if the product requires servicing.

## TO CLEAN:

Always unplug the Toaster and allow to cool fully before cleaning.

**Crumb Tray:** The Crumb Tray is located at the bottom of the Toaster. For ease in cleaning, grasp the Crumb Tray by the grip and push toward the side of the Toaster to avoid the tab on the bottom.

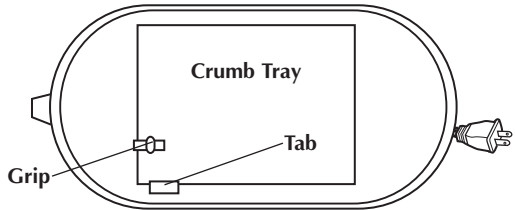

Brush crumbs from the Tray and, if necessary, wipe with a clean, damp cloth. Always dry the Crumb Tray thoroughly before replacing. When closing the Tray, be sure to push firmly until the tab fits snugly up against the bottom of the Toaster.

**Exterior:** Wipe surfaces with a clean, damp cloth. Do not use abrasive cleaners, as they may scratch the surface.

## TO STORE:

Unplug unit, allow to cool, and clean before storing. Store in its box in a clean, dry place. Never store it while it is hot or still plugged in. Never wrap cord tightly around the appliance, use the Cord Storage Compartment located at one end of the Toaster. Do not put any stress on the cord where it enters the unit, as it could cause the cord to fray and break.

# FARBERWARE®

## ONE-YEAR LIMITED WARRANTY

**Warranty:** This Farberware® product is warranted by Salton, Inc. to be free from defects in materials or workmanship for a period of (1) year from the original purchase date. This product warranty covers only the original consumer purchaser of the product.

**Warranty Coverage:** This warranty is void if the product has been damaged by accident in shipment, unreasonable use, misuse, neglect, improper service, commercial use, repairs by unauthorized personnel, normal wear and tear, improper assembly, installation or maintenance abuse or other causes not arising out of defects in materials or workmanship. This warranty is effective only if the product is purchased and operated in the USA, and does not extend to any units which have been used in violation of written instructions furnished with the product or to units which have been altered or modified or to damage to products or parts thereof which have had the serial number removed, altered, defaced or rendered illegible.

**Implied Warranties:** ANY IMPLIED WARRANTIES WHICH THE PURCHASER MAY HAVE ARE LIMITED IN DURATION TO ONE (1) YEAR FROM THE DATE OF PURCHASE. Some states do not allow limitations on how long an implied warranty lasts, so the above limitation may not apply to you.

**Warranty Performance:** During the above one-year warranty period, a product with a defect will be either repaired or replaced with a reconditioned comparable model (at our option) when the product is returned to the Repair Center, or the purchase price refunded. The repaired or replacement product will be in warranty for the balance of the one-year warranty period and an additional one-month period. No charge will be made for such repair or replacement.

**Service and Repair:** Should the appliance malfunction, you should first call toll-free 1 (888) 881-8101 between the hours of 9:00 am and 5:00 pm Central Standard Time and ask for CONSUMER SERVICE stating that you are a consumer with a problem. Please refer to model number FPT200 when you call.

**In-Warranty Service (USA):** For an appliance covered under the warranty period, no charge is made for service or postage. Call for return authorization 1 (888) 881-8101.

**Out-of-Warranty Service:** A flat rate charge by model is made for out-of-warranty service. Include \$8.00 (U.S.) for return shipping and handling. We will notify you by mail of the amount of the charge for service and require you to pay in advance for the repair or replacement.

**For Products Purchased in the USA, but Used in Canada:** You may return the product insured, packaged with sufficient protection, and postage and insurance prepaid to the USA address listed below. Please note that all customs duty / brokerage fees, if any, must be paid by you and we will require you to pay the cost of customs duty / brokerage fees to us in advance of our performing any service.

**Risk During Shipment:** We cannot assume responsibility for loss or damage during incoming shipment. For your protection, carefully package the product for shipment and insure it with the carrier. Be sure to enclose the following items with your appliance: any accessories related to your problem, your full return address and daytime phone number, a note describing the problem you experienced, a copy of your sales receipt or other proof of purchase to determine warranty status. C.O.D. shipments cannot be accepted.

**To return the appliance, ship to:**

ATTN: Repair Center  
Salton, Inc.  
708 South Missouri Street  
Macon, MO 63552

**To contact us, please write to, call, or email:**

Salton, Inc.  
P.O. Box 7366  
Columbia, MO 65205-7366  
1-888-881-8101  
E-mail: Farberware-electric@Saltonusa.com

**Limitation of Remedies:** No representative or person is authorized to assume for Salton, Inc. any other liability in connection with the sale of our products. There shall be no claims for defects or failure of performance or product failure under any theory of tort, contract or commercial law including, but not limited to negligence, gross negligence, strict liability, breach of warranty and breach of contract. Repair, replacement or refund shall be the sole remedy of the purchaser under this warranty, and **in no event shall Salton be liable for any incidental or consequential damages, losses or expenses.** Some states do not allow the exclusion or limitation of incidental or consequential damages, so the above limitation or exclusion may not apply to you.

**Legal Rights:** This warranty gives you specific legal rights, and you may also have other rights which vary from state to state.

©2002 Salton, Inc. All rights reserved.

FARBERWARE® is a registered trademark of Farberware Inc.®

Manufactured and sold pursuant to a license from Farberware Inc.®